

BN 3332

**Vtlačovací závitové svorníky**

Ocel tepelne zušlechťeno 300-380 HV  
pozinkováno modře



ISO 4042

Spojovací díly s tvrdostí  $\geq 320$  HV s elektrolytickými povlaky:  
náchylné na vodíkovou křehkost!  
Další poznámky k možným rizikům jsou uvedeny v úvodní  
části.

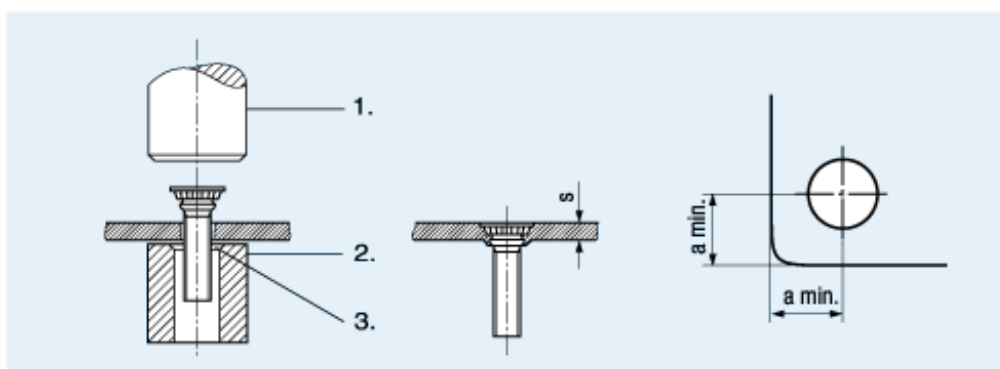

- 1. Razník
- 2. Matrice
- 3. Sražení min.  $0,5 \times 90^\circ$

Article#	d <sub>1</sub>	d <sub>2</sub>	s min.	Průměr otvoru +0,08/0	a min.	L
1536486	M3	5	1	3	6	6
1536494						8
1536508						10
1536516						12
1536524						14
1536532						16
1536540						18
1536559						20
3056401	M4	6	1,2	4	6	8
1536567						10
1536575						12
1536583						14
1536591						16
1536605						18
1536613						20
1536621						25

Article#	d <sub>1</sub>	d <sub>2</sub>	s min.	Průměr otvoru +0,08/0	a min.	L
1536648	M5	7	1,3	5	8	10
1536656						12
1536664						14
1536672						16
1536680						18
1536699						20
1536729	M6	8	1,5	6	8	12
1536737						14
1536745						16
1536753						18
1536761						20
1536788						25
1536796						30